

# Forged Steel Ball Valve

## 800LB/1500LB/2500LB

# ZQV

## F2 Series



API 607 Firesafe  
Certified



### Specifications:

- ❖ 2 PIECE FORGED STEEL BODY
- ❖ Size: 1/4" to 4"
- ❖ Pressure: 800LB/1500LB/2500LB  
2000PSI/3000PSI/5000PSI/6000PSI
- ❖ BLOW OUT PROOF STEM
- ❖ DELRIN/RPTFE/PEEK SEAT
- ❖ Threadeds Conform to ASME B1.20.1(NPT)
- ❖ NACE MR-01-75(Optional)
- ❖ API 607 FireSafe
- ❖ Locking Handle Design(Optional)
- ❖ Inspection and Test :API 598

### Parts & Materials

NO.	Parts	Material		
1	BODY	ASTM A105	A182 F304	A182 316
2	CAP	ASTM A105	A182 F304	A182 316
3	BALL	SS304	SS304	SS316
4	SEAT	RPTFE / DELRIN / PEEK		
5	STEM	SS304	SS304	SS316
6	HANDLE	SS201		
7	BODY O-RING	VITON		
8	STEM NUT	A2-70		
9	WASHER	SS301		
10	BODY GASKET	SS+Graphite / RPTFE		
11	PACKING	Graphite / RPTFE		



ZHEJIANG ZHENGQIU VALVE CO.,LTD  
High and new industrial zone  
Yongzhong, Wenzhou,Zhejiang  
China 325024

Tel:+86 577 86911288  
Fax:+86 577 86911558  
E-mail:Sale@cnballvalve.com

WWW.CNBALLVALVE.COM  
WWW.GOODBALLVALVES.COM

# Forged Steel Ball Valve

## 800LB/1500LB/2500LB

# ZQV

## F2 Series

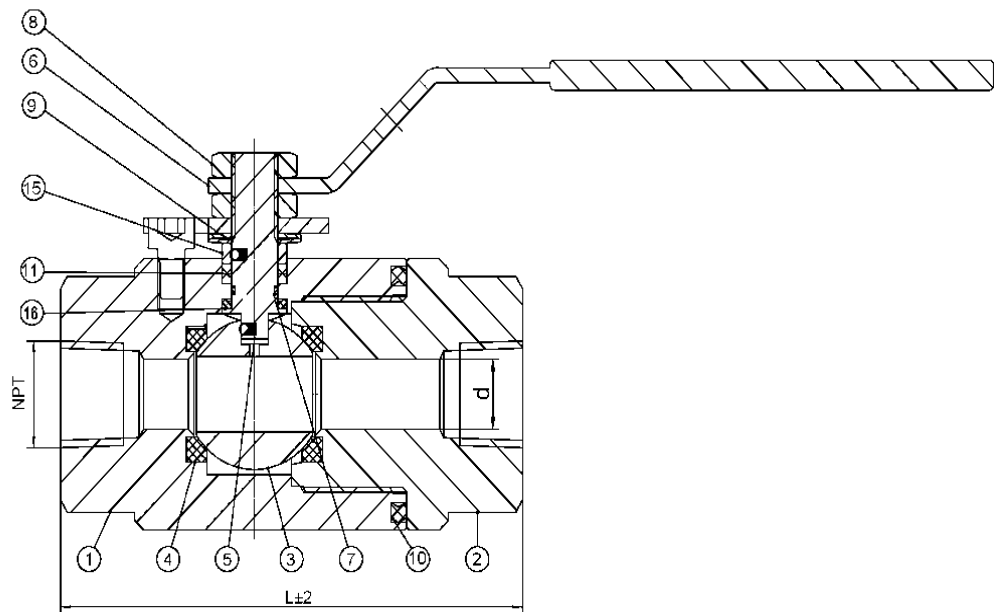

### Dimensions

Size	CLASS800(2000PSI)				CLASS1500(3000PSI)				CLASS2500(6000PSI)				NPT
	L		d		L		d		L		d		
	mm	Inch	mm	Inch	mm	Inch	mm	Inch	mm	Inch	mm	Inch	
1/4"	70	2.76	10	0.40	70	2.76	10	0.40	75	2.96	10	0.40	1/4"-18NPT
3/8"	70	2.76	10	0.40	70	2.76	10	0.40	85	3.35	10	0.40	3/8"-18NPT
1/2"	85	3.35	13	0.50	85	3.35	13	0.50	100	3.94	13	0.50	1/2"-14NPT
3/4"	95	3.75	20	0.75	95	3.75	20	0.75	120	4.73	20	0.75	3/4"-14NPT
1"	105	4.14	25	1.00	105	4.14	25	1.00	135	5.32	25	1.00	1"-11.5NPT
1-1/4"	120	4.73	32	1.25	120	4.73	32	1.25	160	6.30	32	1.25	1.25"-11.5NPT
1-1/2"	130	5.12	38	1.50	130	5.12	38	1.50	185	7.29	38	1.50	1.5"-11.5NPT
2"	150	5.91	50	2.00	150	5.91	50	2.00	220	8.67	48	2.00	2"-11.5NPT



**ZHEJIANG ZHENGQIU VALVE CO.,LTD**  
 High and new industrial zone  
 Yongzhong, Wenzhou, Zhejiang  
 China 325024

Tel: +86 577 86911288  
 Fax: +86 577 86911558

[WWW.CNBALLVALVE.COM](http://WWW.CNBALLVALVE.COM)